

Strobe light STR2

Comax
Signaltechnik

General information

Compact and efficient strobe light with a broad tension range. High degree of protection IP65.

For applications in the machine industry or in building control.

Technical data

Dimensions	Ø 60mm x 80mm
Case	PC
-colour	black
Lens	PC
-colours	red, amber, yellow, green, blue, clear
Strobe intensity	1Joule
Frequency	0,75Hz
Output	37cd (clear dome)
Temperatur range	-25°C up to +50°C
Construction	Bayonet with anti-tamper locking screw
Operation	continuous
Installation	Surface, wall, stand
Connection	Cable entry through bottom Ø 8mm
Degree of protection	IP65 according to EN60529
Weight	78g

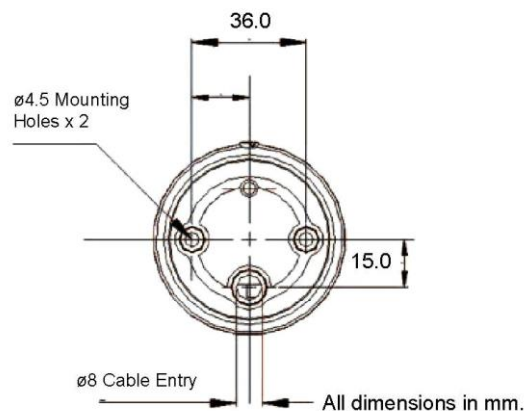
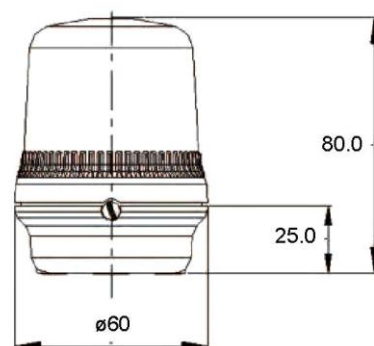

Order data

No. of article	Nominal tension	Light output	Current consumption
STR2.024.3*	10-30VAC/VDC	1J	135mA
STR2.115.7*	115VAC 50/60Hz	1J	30mA
STR2.230.7*	230VAC 50/60Hz	1J	20mA

Lens colours

1 = red, 2 = amber, 3 = yellow, 4 = green, 5 = blue, 7 = clear

Options

Wall mounting angle, stand (140mm)

Technical modifications without prior notice



Comax
Signaltechnik

Comax Industrielle Signaltechnik AG, Römerstrasse 6/Postfach, CH-4512 Bellach/Schweiz
Tel +41-(0)32-617 31 41 Fax +41-(0)32-617 31 40 e-mail: mail@comax.ch internet: www.comax.ch